

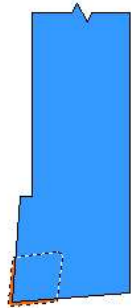

# Lathe Tool List

Library: Sorted: No Filtered: Yes Date & Time: 10/20/2015 5:47 PM  
 V:\VARCO REPORTING\MASTERCAM PART FILES\LATHE TOOL LIST EXAMPLE.MCX-9

### T0101:

	Tool Type: General Turning Tool	Coolant: Off	
	Mfg. Code:	Spindle Dir.: CCW	
	Turret: Upper	Spindle Speed: 200 CSS	
	Spindle: Left	Fast Feed: 0.01 inch/rev	
	Units: Inch	Slow Feed: 0.005 inch/rev	
	Holder	Insert	
	Name: DCGNR-164D	Name: CNMG-432	
	Length:	Shape: C (80 deg.)	
	Width: 1.25"	Radius: 0.0313"	
	Orientation: Vertical	Material: Carbide	
	Hand: Right		
	Angle: 0.0°		

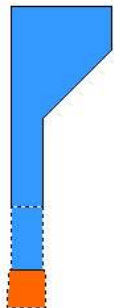

### T4646:

	Tool Type: Grooving Tool	Coolant: Off	
	Mfg. Code:	Spindle Dir.: CCW	
	Turret: Upper	Spindle Speed: 200 CSS	
	Spindle: Left	Fast Feed: 0.006 inch/rev	
	Units: Inch	Slow Feed: 0.004 inch/rev	
	Holder	Insert	
	Name:	Name: GCP-4250	
	Length:	Shape: E (75 deg.)	
	Width: 0.5"	Radius: 0.01"	
	Orientation: Vertical	Material: Carbide	
	Hand: Right		
	Angle: 0.0°		

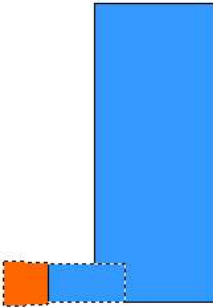

### T6363: FACE GROOVE RIGHT - WIDE

	Tool Type: Grooving Tool	Coolant: Off	
	Mfg. Code:	Spindle Dir.: CCW	
	Turret: Upper	Spindle Speed: 200 CSS	
	Spindle: Left	Fast Feed: 0.006 inch/rev	
	Units: Inch	Slow Feed: 0.004 inch/rev	
	Holder	Insert	
	Name:	Name:	
	Length:	Shape: E (75 deg.)	
	Width: 1.75"	Radius: 0.008"	
	Orientation: Vertical	Material: Carbide	
	Hand: Right		
	Angle: 0.0°		





### T7373:

	Tool Type: Boring Tool	Coolant: Off	
	Mfg. Code:	Spindle Dir.: CCW	
	Turret: Upper	Spindle Speed: 200 CSS	
	Spindle: Left	Fast Feed: 0.01 inch/rev	
	Units: Inch	Slow Feed: 0.005 inch/rev	
	Holder	Insert	
	Name:	Name:	
	Length:	Shape: E (75 deg.)	
	Width: 0.25"	Radius: 0.0156"	
	Orientation: Horizontal	Material: Carbide	
	Hand: Right		
	Angle: 0.0°		





**T9797:**

 Tool Type: Threading Tool	Coolant: Off	
Mfg. Code:	Spindle Dir.: CCW	
Turret: Upper	Spindle Speed: 200 RPM	
Spindle: Left	Fast Feed: 20.0 inch/min	
Units: Inch	Slow Feed: 0.0 inch/min	
<u>Holder</u>		
Name:	Insert Name:	
Length:	Shape: R (round)	
Width: 1.0"	Radius: 0.0144"	
Orientation: Vertical	Material: Carbide	
Hand: Right		
Angle: 0.0°		

**T100100: Custom General Turning**

 Tool Type: Custom Tool	Coolant: Flood	
Mfg. Code:	Spindle Dir.: CCW	
Turret: Upper	Spindle Speed: 200 CSS	
Spindle: Left	Fast Feed: 0.01 inch/rev	
Units: Inch	Slow Feed: 0.005 inch/rev	
<u>Custom</u>	Geo. Orient: 1	
Type: General Turning Tool		
Radius: 0.0313"		
Turret Orient: 1		

**T110110: Custom- Threading**

 Tool Type: Custom Tool	Coolant: Off	
Mfg. Code:	Spindle Dir.: CCW	
Turret: Upper	Spindle Speed: 200 RPM	
Spindle: Left	Fast Feed: 20.0 inch/min	
Units: Inch	Slow Feed: 0.0 inch/min	
<u>Custom</u>	Geo. Orient: 1	
Type: Threading Tool		
Radius: 0.01"		
Turret Orient: 1		

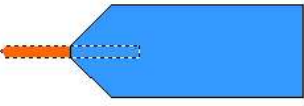
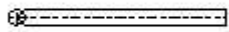

**T111111: SPOT TOOL .25 DIA.**

 Tool Type: Countersink	Coolant: Off	
Mfg. Code:	Spindle Dir.: CCW	
Turret: Upper	Spindle Speed: 200 RPM	
Spindle: Left	Fast Feed: 0.01 inch/rev	
Units: Inch	Slow Feed: 0.0 inch/min	
<u>Holder</u>		
Name:	Tool Name:	
Length:	Material: Carbide	
Width: 2.0"	Diameter: 0.25"	
Orientation: Horizontal	Shank Dia.: 0.25"	
Hand: Right	Cut Length: 1.5"	
Angle: 0.0°	Flute Length: 1.5"	
	Flutes: 2	
	Tip Angle: 90.0°	

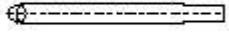
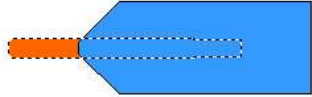
**T111111: 7/16" Reamer**

	Tool Type: Reamer		Coolant: Off	
	Mfg. Code:		Spindle Dir.: CCW	
	Turret: Upper	Lng. Offset: 111	Spindle Speed: 200 RPM	
	Spindle: Left	Insert Up: No	Fast Feed: 0.01 inch/rev	
	Units: Inch		Slow Feed: 0.0 inch/min	
	<u>Holder</u>	<u>Tool</u>		
	Name:	Material: Carbide		
	Length:	Diameter: 0.4375"		
	Width: 2.0"	Shank Dia.: 0.375"		
Orientation: Horizontal		Cut Length: 4.0"		
Hand: Right		Flute Length: 3.75"		
Angle: 0.0°		Flutes: 6		
		Flute Angle: 0.0°		
		Tip Angle: 118.0°		

**T115115: RH Tap 16 THd/Inch**

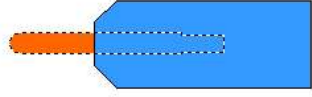
	Tool Type: RH Tap		Coolant: Flood	
	Mfg. Code:		Spindle Dir.: CCW	
	Turret: Upper	Lng. Offset: 115	Spindle Speed: 200 RPM	
	Spindle: Left	Insert Up: No	Fast Feed: 0.0625 inch/rev	
	Units: Inch			
	<u>Holder</u>	<u>Tool</u>		
	Name:	Material: Carbide		
	Length:	Diameter: 0.5"		
	Width: 2.0"	Shank Dia.: 0.375"		
Orientation: Horizontal		Cut Length: 4.0"		
Hand: Right		Flute Length: 3.75"		
Angle: 0.0°		Flutes: 4		
		Flute Angle: 0.0°		
		Tip Angle: 118.0°		
		Tap Type: Tapered		
		Threads: Infinity		

**T116116: 1/2" Endmill**

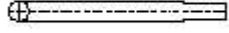
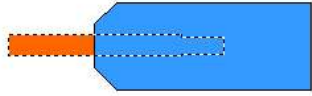

	Tool Type: End Mill		Coolant: Off	
	Mfg. Code:		Spindle Dir.: CCW	
	Turret: Upper	Lng. Offset: 116	Spindle Speed: 200 RPM	
	Spindle: Left	Insert Up: No	Fast Feed: 0.01 inch/rev	
	Units: Inch		Slow Feed: 0.0 inch/min	
	<u>Holder</u>	<u>Tool</u>		
	Name:	Material: Carbide		
	Length:	Diameter: 0.5"		
	Width: 2.0"	Shank Dia.: 0.375"		
Orientation: Horizontal		Cut Length: 4.0"		
Hand: Right		Flute Length: 3.75"		
Angle: 0.0°		Flutes: 2		
		Flute Angle: 30.0°		

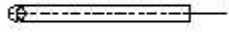
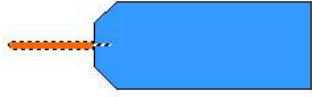

**T116116: LH Tap 5 x1 mm**

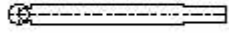

	Tool Type: LH Tap		Coolant: Flood	
	Mfg. Code:		Spindle Dir.: CCW	
	Turret: Upper	Lng. Offset: 116	Spindle Speed: 200 RPM	
	Spindle: Left	Insert Up: No	Fast Feed: 0.0012 inch/rev	
	Units: Inch			
	<u>Holder</u>	<u>Tool</u>		
	Name:	Material: Carbide		
	Length:	Diameter: 5.0"		
	Width: 2.0"	Shank Dia.: 0.375"		
Orientation: Horizontal		Cut Length: 50.0"		
Hand: Right		Flute Length: 40.0"		
Angle: 0.0°		Flutes: 4		
		Flute Angle: 0.0°		
		Tip Angle: 118.0°		
		Tap Type: Plug		
		Threads: Infinity		

**T117117: 1/2" Counterbore**



	Tool Type: Counterbore		Coolant: Off	
	Mfg. Code:		Spindle Dir.: CCW	
	Turret: Upper	Lng. Offset: 117	Spindle Speed: 200 RPM	
	Spindle: Left	Insert Up: No	Fast Feed: 0.0394 inch/rev	
	Units: Inch		Slow Feed: 0.0 inch/min	
	<u>Holder</u>	<u>Tool</u>		
	Name:	Material: Carbide		
	Length:	Diameter: 0.5"		
	Width: 2.0"	Shank Dia.: 0.375"		
	Orientation: Horizontal	Cut Length: 4.0"		
	Hand: Right	Flute Length: 0.0001"		
	Angle: 0.0°	Flutes: 2		
		Flute Angle: 30.0°		
		Tip Angle: 0.0°		
		Tip Diameter: 0.25"		



**T120120: Custom- Groove**

	Tool Type: Custom Tool		Coolant: Off	
	Mfg. Code:		Spindle Dir.: CCW	
	Turret: Upper	Lng. Offset: 120	Spindle Speed: 200 RPM	
	Spindle: Left	Insert Up: No	Fast Feed: 0.01 inch/rev	
	Units: Inch		Slow Feed: 0.0 inch/min	
	<u>Custom</u>		Geo. Orient: 1	
	Type: Grooving Tool			
	Radius: 0.01"			
	Turret Orient: 1			



**T122122: #4 Center Drill**



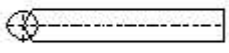
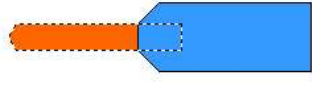

	Tool Type: Center Drill		Coolant: Off	
	Mfg. Code:		Spindle Dir.: CCW	
	Turret: Upper	Lng. Offset: 122	Spindle Speed: 200 RPM	
	Spindle: Left	Insert Up: No	Fast Feed: 0.01 inch/rev	
	Units: Inch		Slow Feed: 0.0 inch/min	
	<u>Holder</u>	<u>Tool</u>		
	Name:	Material: Carbide		
	Length:	Diameter: 0.4375"		
	Width: 2.0"	Shank Dia.: 0.375"		
	Orientation: Horizontal	Cut Length: 1.5"		
	Hand: Right	Flute Length: 0.75"		
	Angle: 0.0°	Flutes: 2		
		Flute Angle: 30.0°		
		Tip Angle: 60.0°		



**T125125: DRILL .75 DIA.**

	Tool Type: Drill		Coolant: Off	
	Mfg. Code:		Spindle Dir.: CCW	
	Turret: Upper	Lng. Offset: 125	Spindle Speed: 200 RPM	
	Spindle: Left	Insert Up: No	Fast Feed: 0.01 inch/rev	
	Units: Inch		Slow Feed: 0.0 inch/min	
	<u>Holder</u>	<u>Tool</u>		
	Name:	Material: Carbide		
	Length:	Diameter: 0.75"		
	Width: 2.0"	Shank Dia.: 0.75"		
	Orientation: Horizontal	Cut Length: 4.0"		
	Hand: Right	Flute Length: 3.75"		
	Angle: 0.0°	Flutes: 2		
		Flute Angle: 70.0°		
		Tip Angle: 118.0°		

**T130130: Custom- Boring**

 Tool Type: Custom Tool		Coolant: Off	
 Mfg. Code:		Spindle Dir.: CCW	
Turret: Upper	Lng. Offset: 130	Spindle Speed: 200 RPM	
Spindle: Left	Insert Up: No	Fast Feed: 20.0 inch/min	
Units: Inch		Slow Feed: 0.0 inch/min	
<u>Custom</u>		Geo. Orient: 8	
Type: Boring Tool			
Radius: 0.0156"			
Turret Orient: 8	