





Tool List for "T.NC" (Not Sorted)

Lathe- T6363: FACE GROOVE RIGHT - WIDE

	Tool Type: Grooving Tool		Coolant: Off	
	Mfg. Code:		Spindle Dir.: CCW	
	Turret: Upper	Offset- Front: 63	Spindle Speed: 200 CSS	
	Spindle: Left	Offset- Back: 63	Fast Feed: 0.006 inch/rev	
	Units: Inch	Insert Up: No	Slow Feed: 0.004 inch/rev	
	<u>Holder</u>	<u>Insert</u>		
	Name:	Name:		
	Length:	Shape: E (75 deg.)		
	Width: 1.75"	Radius: 0.008"		
	Orientation: Vertical	Material: Carbide		
	Hand: Right			
	Angle: 0.0°			

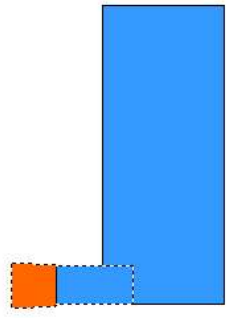
Tool- Coolant is Off

Lathe- T125125: DRILL .75 DIA.

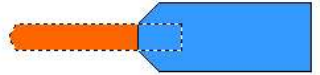
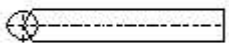
	Tool Type: Drill		Coolant: Off	
	Mfg. Code:		Spindle Dir.: CCW	
	Turret: Upper	Lng. Offset: 125	Spindle Speed: 200 RPM	
	Spindle: Left	Insert Up: No	Fast Feed: 0.01 inch/rev	
	Units: Inch		Slow Feed: 0.0 inch/min	
	<u>Holder</u>	<u>Tool</u>		
	Name:	Material: Carbide		
	Length:	Diameter: 0.75"		
	Width: 0.0"	Shank Dia.: 0.75"		
	Orientation: Horizontal	Cut Length: 4.0"		
	Hand: Right	Flute Length: 3.75"		
	Angle: 0.0°	Flutes: 2		
		Flute Angle: 70.0°		
		Tip Angle: 118.0°		

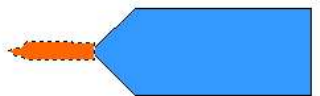
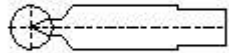

Tool- Coolant is Off

Lathe- T122122: #4 Center Drill

	Tool Type: Center Drill		Coolant: Off	
	Mfg. Code:		Spindle Dir.: CCW	
	Turret: Upper	Lng. Offset: 122	Spindle Speed: 200 RPM	
	Spindle: Left	Insert Up: No	Fast Feed: 0.01 inch/rev	
	Units: Inch		Slow Feed: 0.0 inch/min	
	<u>Holder</u>	<u>Tool</u>		
	Name:	Material: Carbide		
	Length:	Diameter: 0.4375"		
	Width: 0.0"	Shank Dia.: 0.375"		
	Orientation: Horizontal	Cut Length: 1.5"		
	Hand: Right	Flute Length: 0.75"		
	Angle: 0.0°	Flutes: 2		
		Flute Angle: 30.0°		
		Tip Angle: 60.0°		

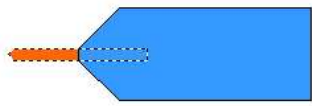

Tool- Coolant is Off

Lathe- T11111: SPOT TOOL .25 DIA.

	Tool Type: Countersink Mfg. Code:		Coolant: Off Spindle Dir.: CCW Spindle Speed: 200 RPM Fast Feed: 0.01 inch/rev Slow Feed: 0.0 inch/min	
	Turret: Upper Spindle: Left Units: Inch	Lng. Offset: 111 Insert Up: No		
	<u>Holder</u>	<u>Tool</u>		
	Name:	Material: Carbide		
	Length:	Diameter: 0.25"		
	Width: 0.0"	Shank Dia.: 0.25"		
	Orientation: Horizontal	Cut Length: 1.5"		
	Hand: Right	Flute Length: 1.5"		
	Angle: 0.0°	Flutes: 2		
		Tip Angle: 90.0°		

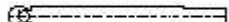

Tool- Coolant is Off

Lathe- T117117: 1/2" Counterbore

	Tool Type: Counterbore Mfg. Code:		Coolant: Off Spindle Dir.: CCW Spindle Speed: 200 RPM Fast Feed: 0.0394 inch/rev Slow Feed: 0.0 inch/min	
	Turret: Upper Spindle: Left Units: Inch	Lng. Offset: 117 Insert Up: No		
	<u>Holder</u>	<u>Tool</u>		
	Name:	Material: Carbide		
	Length:	Diameter: 0.5"		
	Width: 0.0"	Shank Dia.: 0.375"		
	Orientation: Horizontal	Cut Length: 4.0"		
	Hand: Right	Flute Length: 0.0001"		
	Angle: 0.0°	Flutes: 2		
		Flute Angle: 30.0°		
		Tip Angle: 0.0°		
		Tip Diameter: 0.25"		

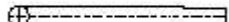

Tool- Coolant is Off

Lathe- T116116: 1/2" Endmill

	Tool Type: End Mill Mfg. Code:		Coolant: Off Spindle Dir.: CCW Spindle Speed: 200 RPM Fast Feed: 0.01 inch/rev Slow Feed: 0.0 inch/min	
	Turret: Upper Spindle: Left Units: Inch	Lng. Offset: 116 Insert Up: No		
	<u>Holder</u>	<u>Tool</u>		
	Name:	Material: Carbide		
	Length:	Diameter: 0.5"		
	Width: 0.0"	Shank Dia.: 0.375"		
	Orientation: Horizontal	Cut Length: 4.0"		
	Hand: Right	Flute Length: 3.75"		
	Angle: 0.0°	Flutes: 2		
		Flute Angle: 30.0°		



Tool- Coolant is Off

Lathe- T11111: 7/16" Reamer

	Tool Type: Reamer Mfg. Code:		Coolant: Off Spindle Dir.: CCW Spindle Speed: 200 RPM Fast Feed: 0.01 inch/rev Slow Feed: 0.0 inch/min	
	Turret: Upper Spindle: Left Units: Inch	Lng. Offset: 111 Insert Up: No		
	<u>Holder</u>	<u>Tool</u>		
	Name:	Material: Carbide		
	Length:	Diameter: 0.4375"		
	Width: 0.0"	Shank Dia.: 0.375"		
	Orientation: Horizontal	Cut Length: 4.0"		
	Hand: Right	Flute Length: 3.75"		
	Angle: 0.0°	Flutes: 6		
		Flute Angle: 0.0°		
		Tip Angle: 118.0°		

Tool- Coolant is Off



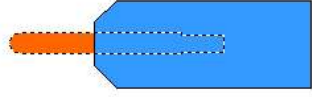

Lathe- T115115: RH Tap 16 THd/Inch

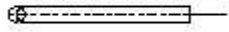
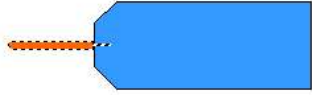
	Tool Type: RH Tap Mfg. Code: Turret: Upper Spindle: Left Units: Inch <u>Holder</u> Name: Length: Width: 0.0" Orientation: Horizontal Hand: Right Angle: 0.0°	Lng. Offset: 115 Insert Up: No <u>Tool</u> Material: Carbide Diameter: 0.5" Shank Dia.: 0.375" Cut Length: 4.0" Flute Length: 3.75" Flutes: 4 Flute Angle: 0.0° Tip Angle: 118.0° Tap Type: Tapered Threads: Infinity	Coolant: Flood Spindle Dir.: CCW Spindle Speed: 200 RPM Fast Feed: 0.0625 inch/rev	 
---	---	---	---	--





Lathe- T116116: LH Tap 5 x1 mm

	Tool Type: LH Tap Mfg. Code: Turret: Upper Spindle: Left Units: Inch <u>Holder</u> Name: Length: Width: 0.0" Orientation: Horizontal Hand: Right Angle: 0.0°	Lng. Offset: 116 Insert Up: No <u>Tool</u> Material: Carbide Diameter: 5.0" Shank Dia.: 0.375" Cut Length: 50.0" Flute Length: 40.0" Flutes: 4 Flute Angle: 0.0° Tip Angle: 118.0° Tap Type: Plug Threads: Infinity	Coolant: Flood Spindle Dir.: CCW Spindle Speed: 200 RPM Fast Feed: 0.0012 inch/rev	 
---	---	---	---	--

Lathe- T100100: Custom General Turning





	Tool Type: Custom Tool Mfg. Code: Turret: Upper Spindle: Left Units: Inch <u>Custom</u> Type: General Turning Tool Radius: 0.0313" Turret Orient: 1	Lng. Offset: 100 Insert Up: No	Coolant: Flood Spindle Dir.: CCW Spindle Speed: 200 CSS Fast Feed: 0.01 inch/rev Slow Feed: 0.005 inch/rev Geo. Orient: 1	  
---	---	-----------------------------------	--	---

Lathe- T110110: Custom- Threading

	Tool Type: Custom Tool Mfg. Code: Turret: Upper Spindle: Left Units: Inch <u>Custom</u> Type: Threading Tool Radius: 0.01" Turret Orient: 1	Lng. Offset: 110 Insert Up: No	Coolant: Off Spindle Dir.: CCW Spindle Speed: 200 RPM Fast Feed: 10.0 inch/min Slow Feed: 0.0 inch/min Geo. Orient: 1	  
---	---	-----------------------------------	--	---





Tool- Coolant is Off

Lathe- T120120: Custom- Groove

 Tool Type: Custom Tool	Coolant: Off	
 Mfg. Code:	Spindle Dir.: CCW	
Turret: Upper	Spindle Speed: 200 RPM	
Spindle: Left	Fast Feed: 0.01 inch/rev	
Units: Inch	Slow Feed: 0.0 inch/min	
<u>Custom</u>	Geo. Orient: 1	
Type: Grooving Tool		
Radius: 0.01"		
Turret Orient: 1		

Tool- Coolant is Off

Lathe- T130130: Custom- Boring

 Tool Type: Custom Tool	Coolant: Off	
 Mfg. Code:	Spindle Dir.: CCW	
Turret: Upper	Spindle Speed: 200 RPM	
Spindle: Left	Fast Feed: 20.0 inch/min	
Units: Inch	Slow Feed: 0.0 inch/min	
<u>Custom</u>	Geo. Orient: 8	
Type: Boring Tool		
Radius: 0.0156"		
Turret Orient: 8		

Tool- Coolant is Off